

# Ballast Survival When Exposed To Commonly Found Transient Voltages

Gary H. Fox, P.E., *Senior Member, IEEE*, Johnny Whitehead

Reprinted from IAS 2007 IEEE Industry Applications Conference Forty-Second Annual Meeting Sept 23-27, New Orleans, LA. Copyright (c) 2007 IEEE.

This material is posted here with permission of the IEEE. Such permission of the IEEE does not in any way imply IEEE endorsement of any of General Electric's products or services. Internal or personal use of this material is permitted. However, permission to reprint/republish this material for advertising or promotional purposes or for creating new collective works for resale or redistribution must be obtained from the IEEE by writing to [pubs-permissions@ieee.org](mailto:pubs-permissions@ieee.org).

**Abstract—This paper documents testing performed to determine the sensitivity of currently available electronic lighting ballasts for fluorescent lighting to surges which may be created both internal and external to a users facility. The ability of surge protective devices to protect these ballasts from surges is also demonstrated through tests documented in this paper.**

**Index Terms—ballast, lighting, surge, surge protective devices.**

## I. INTRODUCTION

The sensitivity of electronic devices and equipment to transient voltage spikes is well documented and fairly well understood [1]. Transient overvoltages can significantly shorten the life of electronic components, sometimes with just one spike if the voltage peak is high enough. Devices to protect electronic components and equipment have been developed and have a proven track record for ensuring that the protected components can provide service for their intended lifetime even in an environment where surges are common.

The use of electronic ballasts in fluorescent lighting applications is becoming more commonplace. Their increased use is being driven by both government regulations and by the advantages they have over older types of ballasts, which shall be discussed later on in this paper. The sensitivity of electronic ballasts to surges was recently called to question by the ballast failure rate experienced by a retail store company. A testing program to investigate this sensitivity and the ability of surge protection devices (SPDs) to protect electronic ballasts was undertaken. Before this paper discusses the tests themselves, it's important to understand the characteristics of voltage transients, or "surges," that may exist in industrial and commercial power systems.

## II. THE SURGE ENVIRONMENT

Surges are an everyday occurrence in the power distribution systems of industrial and commercial facilities. There are

several sources for surges. On the source side of the service entrance, surges may be caused by lightning, utility switching operations, and transients due to fault clearing [2]. Surges from lightning can be created not only from direct strokes onto

the utility distribution system, but can also be caused by lightning strokes in proximity to power lines, where the surge is transmitted onto the power line via induction. While the surges that enter a facility power system via the service entrance are usually the most severe, they are not the most frequent. The number of surges that may enter the facility from the utility is much less than the quantity of surges that are created internally. Internally created surges are typically caused by the switching of inductive loads, such as electric motors. Capacitor switching can also create transients as well.

## III. ELECTRONIC LIGHTING BALLASTS

### A. Driving The Demand for Electronic Ballasts

Fluorescent lamps are low-pressure gaseous-discharge lamps and require a ballast to operate. The lighting ballast provides the initial voltage necessary to start the lamp, and then regulates its operation. When switched on, the ballast transforms the supply voltage to the starting voltage required to initiate an arc between the lamp's electrodes (cathodes). This arc excites the gases contained in the bulb and produces ultraviolet light energy, which in turn excites the phosphor coating on the bulb wall and produces "fluorescence," that is, visible light.

Magnetic style ballasts have been used for many years. They operate the lamp at the same frequency as the incoming power. While they perform the basic functions adequately, high frequency output electronic ballasts offer several advantages over magnetic ballasts:

- Electronic ballasts are much more efficient than magnetic types. The efficiency of the light can be improved as much as 29% using electronic ballasts.
- A related benefit of higher efficiency is the reduction of waste heat generation. The lower heat given off by electronic ballasts may allow the cooling capacity of HVAC systems to be reduced

G. H. Fox is with GE Consumer & Industrial, Concord, CA 94520 USA (e-mail: [g.fox@ieee.org](mailto:g.fox@ieee.org))

J. Whitehead is with GE Consumer & Industrial, Bonham, TX 75418 USA (e-mail: [johnny.whitehead@ge.com](mailto:johnny.whitehead@ge.com))

or have greater reserve capacity for other heat producers.

- Reduced heat dissipation results in lower ambient temperatures around the ballast, which can lead to longer ballast life.
- Magnetic ballasts typically operate one or two fluorescent lamps while electronic lamp ballasts are available that can operate as many as four lamps.
- While magnetic ballasts can be used to drive several lamps in series, when a lamp fails in these fixtures, all the lamps go dark including the lamps that are still functional. There are electronic ballasts that have been designed for parallel connection of the lamps, which allows the fixture to continue to produce light at reduced levels when one lamp has failed.
- The high frequency output of electronic ballasts results in less audible “hum” and discernable lamp flicker.
- Electronic ballast usage will result in savings in electrical costs, in the form of reduced demand charges as well as reduced energy costs.
- Electronic ballasts will impose lower harmonic currents on the power source than magnetic ballasts. The high frequencies of harmonic currents create additional heating in conductors and lower their effective ampacity. Electronic ballast models are commonly available that have a total harmonic current distortion of less than 14%. A comparative figure for magnetic ballasts is in the 20 – 28% range. It is important to note that the amount of harmonics impressed on the power system are reduced even more by virtue of the lower currents that are drawn by lighting systems employing electronic ballasts compared to that of magnetic ballast systems.
- Electronic ballasts are available in “multi-voltage models” which can be operated over a wide range of voltages, encompassing the two most common voltages: 120Vac and 277Vac. There are two benefits of this feature. First, it eliminates the possibility of installing a ballast with an incorrect voltage rating into a circuit. Secondly, users that have lights applied at both 277/480V and 120/208V in a facility no longer need to stock spare ballasts for each utilization voltage.

The efficiency aspects of electronic ballasts are the primary reasons for its application. Both utilities and legislative bodies at both the state and federal level have noticed the significant savings in energy usage. Utilities favor energy saving devices to avoid capital expenditures associated with upgrading generation and distribution systems to handle growing energy demands. Legislative bodies promote energy savings as a means of lowering our dependence on petroleum

and natural gas, and to decrease carbon dioxide emissions and resulting global warming effects. Financial incentives obtainable from utilities and/or governmental agencies include project cost rebates, low interest loans, and tax deductions.

#### *B. Energy Policy Act of 2005*

The 2005 Energy Policy Act (HR-6) is an omnibus of legislation that regulated and established national minimum efficiency standards and established policy for a broad range of energy issues. In regards to linear fluorescent lighting, the following regulations were adopted: [3] The Act listed new Ballast Efficacy Factors (BEF) that electromagnetic ballasts, sold to fixture manufacturers for operating 4-foot, 8-foot and 8-foot HO (high output) energy saving T12 lamps, must meet, effective January 1, 2009. The previous law had established standards only for standard wattage 4-foot and 8-foot T12 fluorescent lamps. Other aspects of this law include:

- Replacement Ballasts must be marked “For Replacement Only”, and can be packaged in containers of no more than 10 ballasts, and having a total lead extension less than the length of the lamp. Replacement ballasts cannot be manufactured after June 30th, 2010.
- Dimming ballasts must have a dimming capability to reduce light output to 50% light output or less.
- Sign Ballasts used in outdoor signs must be designed for use with two F96T12HO lamps at ambient temperatures of –20 F or less..
- Residential ballasts are allowed to have a power factor of less than 0.90. They are labeled for use only in residential building applications.

The Energy Policy Act of 2005 created significant economic incentives to promote the use of high efficiency electronic ballasts. The Act allowed building owners to deduct the cost of an energy efficiency upgrade project in the year that the project was completed. The deduction is limited to a maximum value of \$1.80 per square foot times the area of the building. Furthermore, this deduction is currently available only for tax years 2006 and 2007. Among the qualifications called for in the law, the energy usage in the building must be 50 percent less than the standard building energy levels prescribed by ASHRAE/IESNA 90.1-2001. While the US Department of Energy (DOE) has been mandated with the task of developing a full rule for upgrades, an interim rule is in effect which allows for lesser deductions if an improvement on the order of 25% to 40% below the levels prescribed by ASHRAE/IESNA 90.1-2001 are achieved. [4]

Buildings owned by the Federal Government are particular targets by the Energy Policy Act for energy efficiency improvement. The law requires Federal facilities to reduce energy consumption 2 percent each year beginning in 2006 and continuing until 2015. New Federal buildings have a goal of exceeding the efficiency requirements of ASHRAE/IESNA 90.1-2004 by at least 30% below that of the “baseline building” efficiency standard, provided the improvements are “life cycle cost effective.” A baseline building is defined as a

building that is otherwise identical to the proposed building but is designed to only meet ASHRAE/IESNA 90.1-2004. “Life cycle cost effective” means that the proposed improvement has a lower life cycle cost than the baseline building design or meets other desirable financial metrics. In obtaining energy efficient products, the law prescribes that Energy Star® products, Federal Energy Management Program (FEMP) designated products, and premium efficiency motors, if available, shall be purchased. [5][6]

#### IV. ELECTRONIC BALLASTS LIFETIME

The common causes of decreased life in electronic ballasts is primarily heat, and the second most common cause is voltage transients.

Installed in the lamp fixture, the electronic ballast generates heat from its normal operation. The lamps in the fixture also generate heat and this combined heat is dissipated through the fixture to the surrounding air. If conditions prevent this heat from properly dissipating, the heat build-up will cause the air temperature to rise and possibly exceed the design service conditions of the ballast. When the ballast is operated in ambient temperatures higher than the normal service conditions, a shortening of the lifetime of the ballast should be expected. Generally speaking, operating a ballast at a temperature that is 10C higher than the normal service temperature will reduce its service life by about one half. Electronic ballasts are designed to have a normal service life in a maximum ambient temperatures of 40C.

##### A. Surge Protection In Electronic Ballasts

The present industry standards are ANSI/IEEE C62.41.1-2002, and C62.41.2-2002 where relative level of transients are described and defined based on the concept of wiring location, i.e., service entrance as opposed to branch circuits.[2][7] These standards define a simplified description of the surge propagation boundaries for a typical electrical distribution system, identified as location Categories A, B and C. According to this concept, Category C includes locations that are external to, and immediately inside the facility with a transition area to include service entrance equipment. Category B locations can include some service entrance, distribution and branch panel locations, while category A will typically include remote branch panel and equipment loads and power receptacles.

The standard for High Frequency Fluorescent Lamp Ballasts, ANSI C82.11-2002 states, “Electronic high-frequency ballasts are more susceptible to line transients than line frequency magnetic ballasts. Therefore, transient protection shall be included. The requirement for this transient protection is in ANSI/IEEE C62.41, Class A operation. The line transient test shall consist of seven strikes of a 100 kHz ring wave, 2.5 kV (higher values may be used as appropriate) level, for both common mode and differential mode.”[8] Although many ballast manufacturers comply with the voluntary requirements of the ANSI 82.11 standard, there are times when the internal protection that comes with the ballast may not be sufficient.

All the major manufacturers of electronic ballasts provide products that comply with C62.41-1991 Category A. But this predecessor to C62.41.2 further subdivided the three categories into three severity levels. The present editions of C62.41.1-2002 and C62.41.2-2002 no longer distinguish severity levels of surge immunity testing for category A and B locations. The surge waveforms that were defined for the least severe level (A1) correspond to the surge waveform described in the ANSI C82.11 requirement stated above. The previous standard’s Category A3 corresponds to the waveforms prescribed by the current C62.41.2 Category A. It is not known whether any ballasts have been certified at the A2 or A3 levels; the manufacturers have not published anything to that effect. This being the case; there is no substantiation that electronic ballasts currently available will withstand Category A waveforms as described in the current standard.

Furthermore, C62.41.2 points out that the category boundaries in a facility between the three categories do not have any sharp boundaries, and it’s possible that portions of the power system could be attributed to either of two possible categories. This leads us to conclude that there is no guarantee that electronic ballasts would be applied in only category A levels. Not only could they be subjected to Category A surges that may exceed the capabilities of the ballast’s internal transient protection, but they might also be subject to surges corresponding to Category B, if they are located in the transitional area of the power system between Category B and Category A. Since electronic ballasts can be at risk to moderate and high level surges, it was desirable to establish whether or not a sample of currently available electronic ballasts could withstand such surges when guarded by only their internal transient protection. It followed then that a test to verify the capabilities of a properly installed SPD to provide adequate protection against these surges was also worthy of investigation. To determine the surge immunity of electronic ballasts at locations where they might be installed under typical circumstances, tests were conducted to explore these questions.

#### V. TESTING

##### A. Testing Unprotected Ballasts

The test plan was based on possible exposure to surge crest levels that could be seen within certain facilities at IEEE C62.41.2 Category B locations. The testing of unprotected ballasts was designed to simulate surge conditions which might be experienced by a ballast in a severe environment over a five year period. Although surges of varying voltage magnitudes can occur randomly, the tests were conducted in two parts which together would encompass the total simulated five year period, beginning with the least severe surges in the first part and continuing with a successively higher severity in the next part. While the majority of locations that electronic lighting ballast are installed will be considered medium or low exposure risk sites, testing was carried out at levels that would represent the highest risk of exposure to both oscillatory and

impulsive type surges. The purpose was to estimate the exposure levels and frequencies that electronic ballasts could typically fail, and if the addition of a SPD could reduce the risk of failure under the most extreme surge exposure environments.

The magnitude and quantity of surges that a ballast might experience were developed from a historical data plot of surge occurrences versus peak voltage levels at unprotected locations, documented in ANSI/IEEE C62.41.1 Figure 14 . This information was extrapolated to a quantity representative of a five year period of statistically possible surge voltages occurring at high exposure locations. High exposure locations, as defined by the standard, are geographical locations that suffer from extensive exposure to lightning or unusually severe switching surges.

This analysis of the historical data plot identified two ANSI/IEE defined surge voltage levels which a ballast might experience in a high exposure location. The ANSI/IEEE C62.41.2 6kV Category B Ring Wave test was chosen to simulate the possible conditions of an indoor lighting system. 6kV/3kA Category B combination wave surges were also selected since they reflect the surges that are statistically possible for locations in more than 70% of North American facilities.

The quantity of surges for which each ballast would be tested and the test results are listed in Table 1. The first series of tests were performed using the Category B ring wave. Ballasts which survived this series were then subjected to surge testing using Category B combination waves. The input current and output frequency of the test ballasts were monitored to determine whether the unit had failed. A ballast was deemed to have failed if either the input current or output frequency deviated by more than 20% from the pre-test values.

The test circuit used is shown in Figure 1. A surge generator was connected to the test ballasts using 100 feet of 12 AWG wire to emulate a typical lighting branch circuit. It should be noted that ballasts applied on shorter circuits could be at risk to higher transient voltage levels. Nominal rated voltage was applied to the ballasts during the course of the surge tests. The test samples were subjected to surge voltages applied in line to neutral mode.

A total of nine ballasts underwent testing. The ballasts selected for testing represented four different ballast manufacturers who are recognized leaders in the industry.

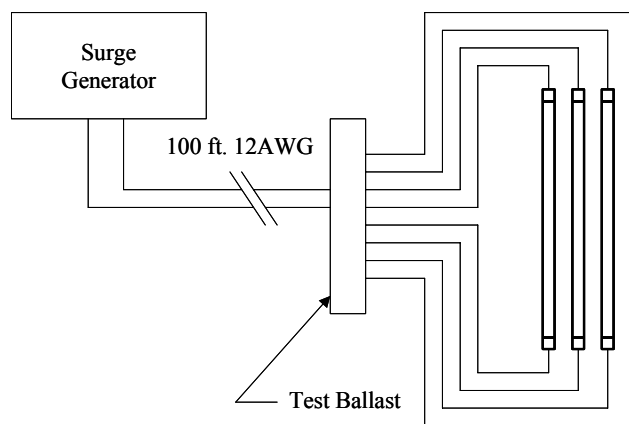

Fig. 1. Test circuit of electronic ballasts with no additional SPD protection applied.

Table 1 lists the quantity of ballasts which survived each of the three tests.

In the initial test series of 500 Category B ring wave surges, only three of the nine test samples survived. Of the ballasts that failed, it was observed that some samples failed after only one Category B ring wave and all failures which occurred at this surge level happened within 25 surges. The testing was continued on the remaining samples using Category B combination waves. In this test, five test surges were scheduled for each sample. However, all of the remaining ballasts failed after only one surge was applied.

As mentioned previously, the Category B ring wave and Category B combination wave are representative of severe surges which could be caused from surge sources both external and internal to a facility. Since none of the test samples were able to survive either one or both of these surges, then electronic ballasts have a demonstrated sensitivity to these severe levels. It is of importance to note that Category B surge voltage levels can occur at medium exposure sites locations. The peak current, rise time and energy transfer will depend on many factors including the surge source, sparkover clearances and system impedance.

#### B. Testing Ballasts on a SPD-Protected Circuit

The test sequence was repeated on new set of samples consisting of the same ballast models as in the first series of tests. However, this test was distinguished by the installation of an SPD to protect the lighting system from transient surges (See Figure 2).

TABLE 1  
TEST RESULTS ON NINE BALLASTS – NO SPD CONNECTED

Surge Type	Qty. of Surges	Results	% Passed	Comments
Ring Wave; 6kV 500 Amp 100kHz;	500	3 – Pass 6 - Fail	33%	Samples typically failed between 1 and 25 surges.
6kV, 3kA 8x20us	5	3 - Fail	0%	All ballasts failed after 1 impulse

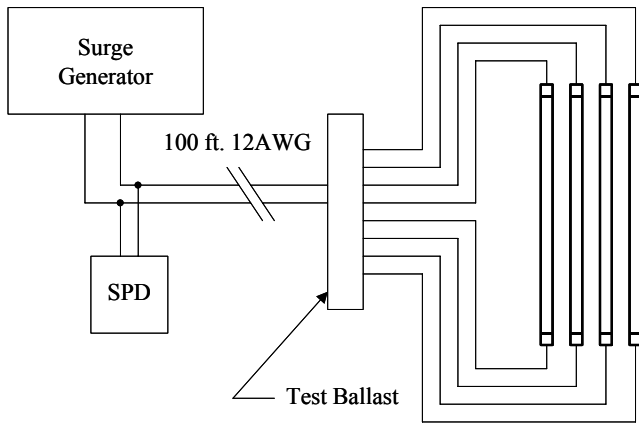

Fig. 2. Test circuit of electronic ballasts with SPD protection applied.

The SPD was attached to the test circuit with 18 inch long

To further investigate the ability of the SPD to protect electronic ballasts, each sample was then subjected to one more surge test using a 1.2x50us, 20kV open circuit voltage, 8x20us, 10kA short circuit combination wave. It is recognized that 20kV is well beyond the sparkover clearances of modern low voltage equipment. Nonetheless it was felt that it would be instructive to see if ballasts on a SPD protected circuit could survive a peak impulse voltage of this severity level.

It was not possible to operate the ballasts at the same time as the surge generation. Operation of the ballasts, through observing the input current and output frequency, was checked before and after this surge test. Again, all of the ballast test samples survived this test and operated within the defined criteria for a functional unit.

The reader may notice that the applied waveform was formerly associated with Category C3 in ANSI/IEEE C62.41-

TABLE 2  
TEST RESULTS ON NINE BALLASTS –TVSS CONNETCED

Surge Type	Qty. of Surges	Results	% Passed	Comments
Ring Wave; 6kV 500 Amp 100kHz;	500	9 - Pass	100%	No sign of degradation or failure
6kV, 3kA 8x20us	5	9 – Pass	100%	No sign of degradation or failure
20 kV, 10 kA 8x20us	1	9 –Pass	100%	No sign of degradation or failure

leads. The lead length with which SPD systems are attached to the equipment they are protecting are a significant factor in the SPD system performance. The surge current that is sunk into the SPD produces a voltage drop across the impedance of the connecting lead length. This voltage adds to the clamping voltage of the SPD and can detract from the overall SPD performance if the lead length is too long. Lead length must be considered when designing a properly applied SPD system. [8]

The SPD used in this test had the following specifications:

1. Maximum surge current rating: 100kA per mode
2. Repetitive surge current rating:5,000 category C impulses
3. UL 1449 edition 2 suppressed voltage rating (L-N): 800V (peak)
4. Category B3/C1 suppressed voltage rating: 843V (peak)

The same series of tests was repeated with new ballast samples. With the SPD protecting them, all of the ballast test samples survived the test and operated within the defined criteria for a functional unit (See Table 2).

1991. The waveform definition for category C was changed in ANSI/IEEE C62.41.2-2002. Since the open circuit voltage of this waveform exceeds the currently defined waveform’s peak voltage, the results stated below would be applicable to tests conducted using the today’s Category C standard).

## VI. ECONOMIC CONSIDERATIONS

### A. The Costs of Ballast Failure

The demonstrated sensitivity of electronic ballasts to surges can subject the end user to significant costs if they remain unprotected. The rate of failure due to surge activity will result in a proportional cost of replacement, assuming the cost to replace each ballast is constant. While the replacement cost for the actual ballast component is not a large amount, other factors may need to be considered to determine the total cost of replacement. The cost caused by the failure to the owner can also include the following:

1. Electrical contractor labor cost to replace the ballast, which typically ranges from \$38/hr to \$75/hr. The premium cost associated with

overtime scheduling may be necessary to avoid disruption of the facility's normal business or production.

2. If the failure affects lighting of product display areas, the resulting dark spots may affect the perceived attractiveness of the product, or the ability of the customer to find the product easily. Either of these could reduce the chance of a purchase being made and a corresponding loss of revenue.
3. The reduced light levels which exist pending replacement may contribute to a safety hazard to customers or employees leading to higher liability risks.

The cost of properly applied SPD equipment in the building power distribution system should be significantly less than the potential life cycle costs that can be attributed to lighting ballast failure due to surges. The investment in a well designed SPD system becomes, in essence, a form of "insurance" to eliminate failures that might be caused by severe surges.

## VII. CONCLUSIONS

In the past, industry has acknowledged the benefits and value of surge protection devices to protect sensitive electronic and computer based products. This testing expands that field of knowledge by demonstrating the need to include solid-state lighting ballasts used in retail, commercial or industrial applications in the list of products that can be subject to transient exposure and requiring additional surge protection when applied in severe environments.

It is widely accepted that the quality of power supplied to both commercial and industrial facilities is expected to continue to decline as increased usage outpaces the ability to supply that power. Internally generated noise and high-speed voltage transients can be generated by computers, laser devices, solid-state switching power supplies and variable speed motors. Historically, many electrical products were not as susceptible to poor power quality, because they used analog based designs (i.e. transformers, capacitors). However, with the growth of solid-state circuitry being designed into everything from lighting ballast to smart appliances, our sensitivity to poor power quality has been raised.

The observed results of the tests showed that electronic ballasts have a sensitivity to surges associated with ANSI/IEEE C62.41.2 Category A and B applications and are likely to fail when subjected to only a low quantity of such surges. But such sensitivity is adequately protected when a properly applied surge protective device is present and can provide protection to surge levels exceeding that which might be physically possible in the facility distribution system.

## REFERENCES

- [1] *IEEE Recommended Practice for Powering and Grounding Electronic Equipment*, IEEE Standard 1100, 1998, pp. 107-128, 235-236.
- [2] *IEEE Guide on the Surge Environment in Low-Voltage (1000 V and less) AC Power Circuits*, IEEE Standard C62.41.1-2002, pp. 4-11
- [3] "10 CFR Parts 430 and 431, Energy Conservation Standards for Certain Consumer Products and Commercial and Industrial Equipment," *Federal Register*, Vol. 70, No. 200, pp. 60412-60413, Oct. 18, 2005.
- [4] "Deduction for Energy Efficient Buildings," Notice 2006-52, *Internal Revenue Bulletin No. 2006-26*, pp.1175-1180, June 26, 2006
- [5] "10 CFR Parts 433, 434 and 435, Energy Conservation Standards for New Federal Commercial and Multi-Family High-Rise Residential Buildings and New Federal Low-Rise Residential Buildings," *Federal Register*, Vol. 71, No. 232, pp. 70275-70284, Dec. 4, 2006.
- [6] *Energy Policy Act of 2005*, Public Law 109-58, August 8, 2005
- [7] *IEEE Recommended Practice on Characterization of Surges in Low-Voltage (1000 V and less) AC Power Circuits*, IEEE Standard C62.41.2-2002, pp. 9
- [8] *American National Standard For Lamp Ballasts, High Frequency Fluorescent Lamp Ballasts*, ANSI Standard C82.11-2002, pp.9
- [9] Marshall, E.; Hander, M.; Valdes, M.; Britton, J.; Jones, T.; Whitehead, J.; McIntyre, B.; "The Influence Of Cable Connections On TVSS Performance," *Industrial and Commercial Power Systems Technical Conference*, pp. 212 – 217, May 8-12, 2005

**Gary H. Fox** (M'89–SM'01) received his BSEE from California Polytechnic State University, San Luis Obispo in 1978. This author became a Member (M) of IEEE in 1989, and a Senior Member (SM) in 2001.

He has been employed by General Electric Company for 28 years. His current assignment is a Systems Engineer for GE Consumer & Industrial in Concord, CA, providing application and technical support for power distribution and control equipment.

Mr. Fox is a member of the IEEE Industry Applications and IEEE Power Engineering Societies. He has held several IEEE officer positions including Chair for the San Francisco Chapter, IAS; Chair, San Francisco Section; and Chair, San Francisco Bay Area Council. He was a recipient of the IEEE Third Millennium Medal. He has been a licensed Professional Engineer since 1982.



**Johnny Whitehead** has been employed by General Electric Company for 19 years. He has held several positions related to the manufacturing, design and testing of AC and DC surge protective devices for telecom, digital systems and commercial / industrial applications.

His current assignment is a TVSS Applications Engineer for GE Consumer & Industrial in Bonham, TX, involved in the design and testing of surge protective device systems, providing application and technical support for industrial and telecom Surge Protective Devices.

