



Surge Protective Devices

TranTrack 2 Series: 065 and 100

Installation,
Operation and
Maintenance
Manual

TABLE OF CONTENTS

Before Installation	3
<i>System Configuration Verification</i>	3
<i>Environmental Condition Verification</i>	4
<i>Wiring Connection Diagrams</i>	4
<i>Upstream Over-Current Protection Device</i>	4
<i>Conductor Routing</i>	4
<i>Mounting</i>	5
<i>Optional Flush Mounting</i>	6
<i>Mounting for 380NN, 480NN, 600NN, 3Y600 voltage</i>	7
<i>Electrical Connections</i>	8
<i>-M Advanced Monitoring Option</i>	8-9
<i>Verification and Power Up</i>	9
Troubleshooting	10
Warranty Statement	10

BEFORE INSTALLATION



WARNING: HAZARDOUS VOLTAGES PRESENT Improper installation or misapplication may result in serious personnel injury and/or damage to electrical system. Read the complete installation instructions before proceeding with installation. Remove all power to the electrical panel before installing or servicing the surge protective device (SPD).

IMPORTANT SAFETY INSTRUCTIONS All work must be performed by licensed and qualified personnel. The electrical system must be properly grounded in accordance with the U.S. National Electrical Code, state and local codes or other applicable codes for this SPD to function properly. This device is suitable for installation where the available short circuit current is 200,000 rms symmetrical amperes at 600VAC or less.



WARNING: Check to ensure that a proper bond is installed between neutral and ground at the transformer upstream from the split-phase or three-phase WYE TransTrack2 device (See NEC Article 250). If the transformer is not accessible, check the main service disconnect/panel for the N-G bond. Lack of a proper bond will damage TransTrack2 and void the warranty.

1. System Configuration Verification

Confirm that the voltage and service configuration shown on the TransTrack2 product label is consistent with the voltage and service configuration of the facility. A model number is located on a label on the outside of unit.

MODEL NUMBER	NOMINAL VOLTAGE	L-N VOLTAGE RANGE	L-L VOLTAGE RANGE	CONFIGURATION
TK-TT2-xxx-1P240	240	N/A	216-264	Single Phase, 2-wire+ground
TK-TT2-xxx-1S240	120/240	108-132	216-264	Split-Phase, 3-wire+ground
TK-TT2-xxx-3Y208	120/208	108-132	187-228	Three-Phase WYE 4-wire+ground
TK-TT2-xxx-3Y380	220/380 230/400	198-242 207-253	342-418 360-440	Three-Phase WYE 4-wire+ground
TK-TT2-xxx-3Y480	277/480	249-305	432-526	Three-Phase WYE 4-wire+ground
TK-TT2-xxx-3D240	120/240	108-132 (A & C PHASES) 187-229 (B PHASE)	216-264	Three-Phase high-leg DELTA 4-wire+ground
TK-TT2-xxx-240NN	240	N/A	216-264	Three-Phase, 3-wire+ground DELTA
TK-TT2-065-380NN	380 400	N/A	342-418 360-440	Three-Phase DELTA 3-wire+ground
TK-TT2-065-480NN	480	N/A	432-528	Three-Phase DELTA 3-wire+ground
TK-TT2-065-600NN	600	N/A	540-660	Three-Phase DELTA 3-wire+ground
TK-TT2-065-3Y600	347/600	312-382	540-660	Three-Phase WYE 4-wire+ground

xxx denotes 65kA or 100kA surge rating per phase.

Suffix at end of model number denotes available options (-M for advanced monitoring package; Form C dry relay contacts and audible alarm with mute button).

2. Environmental Condition Verification

Confirm that the environmental conditions are consistent with the following ranges:

- Ambient Temperatures: Between -40° and +158°F.
- Relative Humidity: Between 5% and 95% non-condensing.
- Altitude: Less than 13,000 feet.

3. Wiring Connection Diagrams

Figure 1 through Figure 5 shows the electrical relationship between TransTrack2 and the service configuration: Single Phase, 2-wire; Split Phase, 3-wire; Three Phase, 4-wire WYE; Three Phase, 3-wire DELTA and Three Phase, 3-wire high-leg DELTA.

Fig. 1: Single Phase, 2-Wire

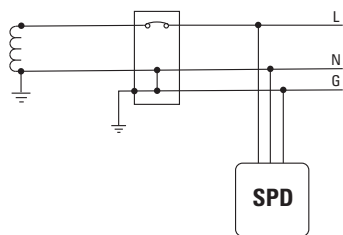

Fig. 2: Split Phase, 3-Wire

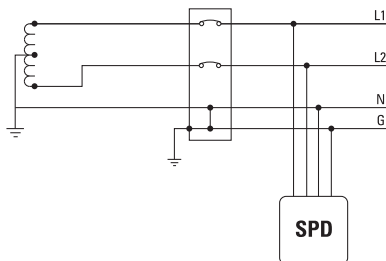

Fig. 3: 3-Phase, 4-Wire WYE

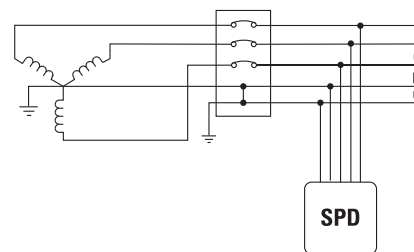

Fig. 4: 3-Phase, 3-Wire DELTA

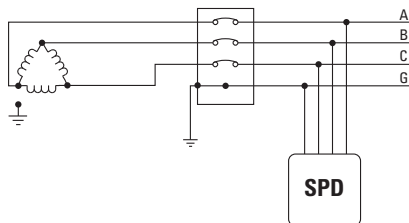
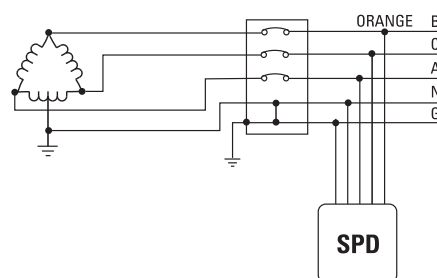

Fig. 5: 3-Phase, 4-Wire High-Leg DELTA



Connections to the SPD are clearly identified and are made via pigtail leads supplied with the unit. For split phase units, the phase connections are marked “A/L1” and “C/L2”. The neutral (when applicable) is a white wire and the ground is a green wire.

4. Upstream Over-Current Protection Device

The TransTrack2 is listed as a Type 1 SPD per UL 1449 3rd Edition, suitable for use in both Type 1 and Type 2 SPD applications. This means that the TransTrack2 can be installed on the line or load side of the main service disconnect. TransTrack2 must be connected in parallel to the electrical system.

TransTrack2 units have built-in over-current fusing rated at 200,000 rms symmetrical ampere at 600VAC or less and can be connected directly to the electrical distribution system bus without an upstream over-current protection device.

The use of a non-fused disconnect or external over-current protection device is recommended as it allows the TransTrack2 to be de-energized during service without disturbing the electrical service to the rest of the facility. If the TransTrack2 is connected to a dedicated over-current protection device, a 30A breaker is recommended (30A minimum, 400A maximum).

5. Conductor Routing



Do not splice TransTrack2's conductors within the unit's enclosure or Manufacturer's warranty will be void. TransTrack2's performance will be limited severely if the conductors are (a) too long, (b) have too many bends or (c) have sharp bends.

The factors listed above should be addressed during the design of an installation to reserve a suitable place for TransTrack2 next to its point of connection to the electrical system. The selected mounting location should allow for the shortest possible conductor runs and a direct route with a minimum of bends. If bends are required, they should be *sweeping* bends (12" radius). Do not make sharp 90° bends for appearance purposes because they will severely decrease the effectiveness of TransTrack 2.

Braiding or twisting conductors together using tie-wraps or electrical tape increases the protection performance of the device. One or two twists or braids of all conductors per foot and securely tie-wrap when conductor lengths must exceed 12".

6. Mounting

TransTrack2 can be mounted in a variety of methods. The basic method is to wall mount using the mounting feet attached to the base of the enclosure. TransTrack2 can also be mounted even (or flush-mount) to the exterior wall surface. Mount TransTrack2 using construction methods and hardware appropriate for your site. The TransTrack2 enclosure is designed with a 3/4-inch myers hub which will accept rigid or IMC conduit. See Figure 6 for enclosure and mounting dimensions.

Fig. 6
Enclosure/Mounting
Dimensions

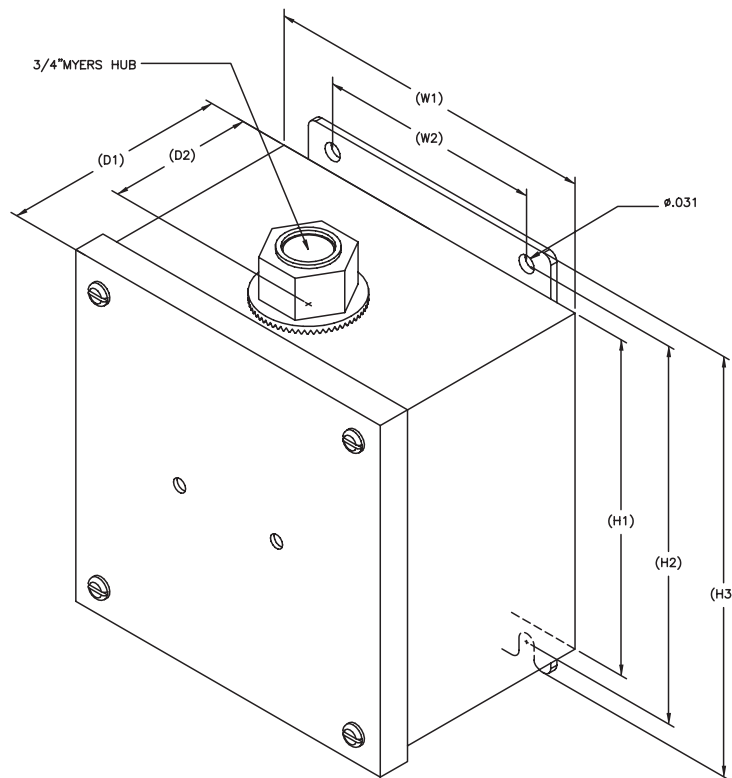

Without Flush Plate

DIM	IN	(mm)
H1	6.00	(152.4)
H2	6.75	(171.5)
H3	7.50	(190.5)
W1	6.00	(152.4)
W2	4.00	(101.6)
D1	4.16	(105.7)
D2	2.50	(63.5)

All measurements in inches (mm)

All voltages except 380NN, 480NN, 600NN and 3Y600

Note: See Figure #8 for dimensions

7. Optional Flush-Mount Plate

(not available for 380NN, 480NN, 600NN, 3Y600 configurations)

Optional flush-mount plate, part number FMP, can be purchased for flush-mount installation. Typically a cutout, larger than the TransTrack2 enclosure, is created in the drywall or other finish material. See Figure 7 for the recommended cutout gap (dimensions L1 and L2). Use the flush-mount plate to hide the gap between the enclosure and the cutout edges. Prior to installation, attach the plate to the enclosure using the existing cover screws.

Fig.7
Flush-Mount Plate
Dimensions

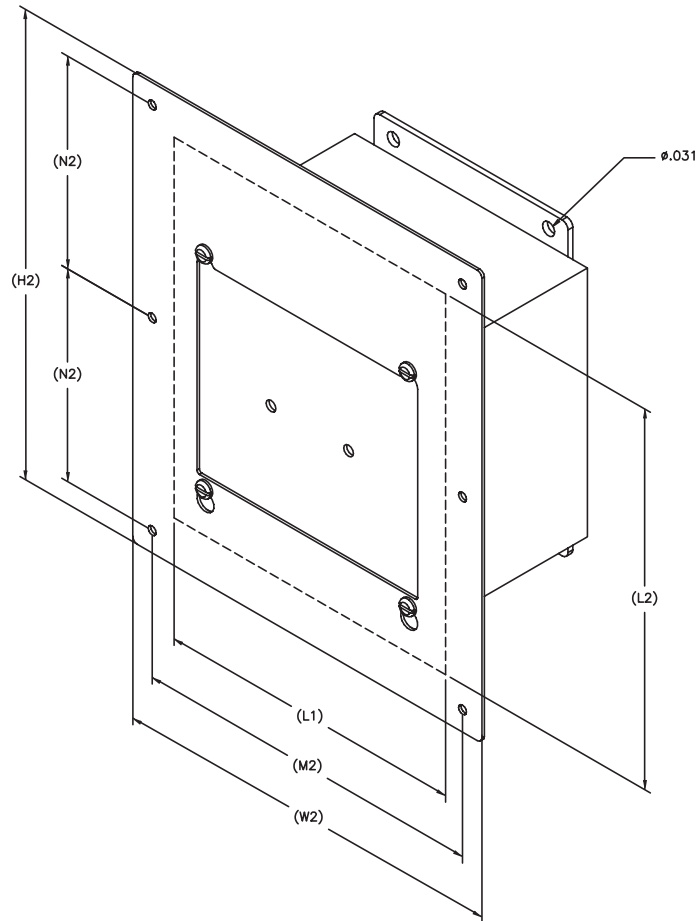

With Flush Plate

DIM	IN	(mm)
H2	10.50	(266.7)
L1	7.00	(177.8)
L2	8.50	(215.9)
M2	8.00	(203.2)
N2	4.75	(120.6)
W2	9.00	(228.6)

All measurements in inches (mm)

Fig. 8 Conduit Openings and Enclosure/Mounting Dimensions for 380NN, 480NN, 600NN and 3Y600

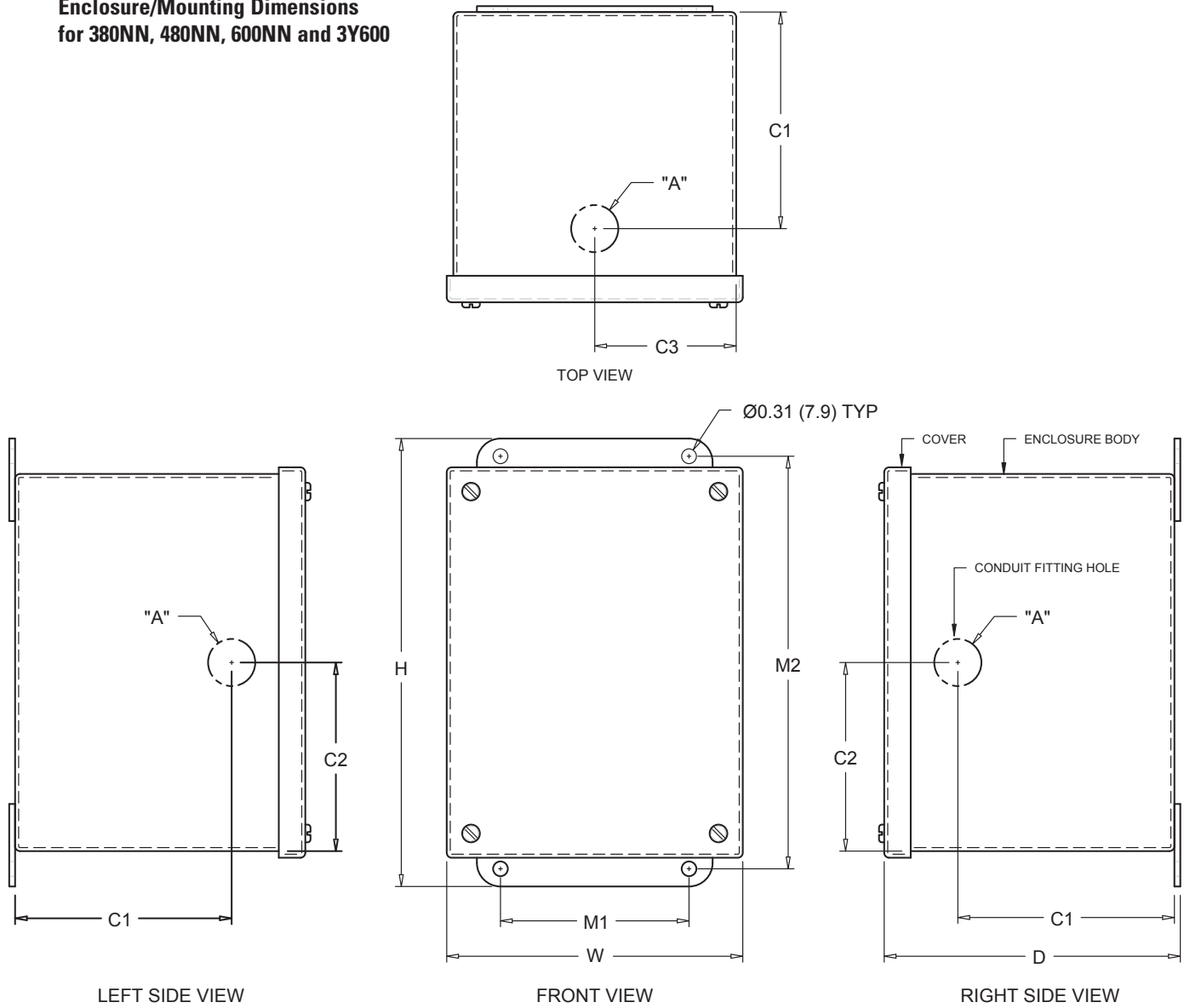

PEAK SURGE RATING	OVERALL DIMENSIONS - IN (mm)					CONDUIT FITTING			
	H	W	D	MOUNTING HOLES		TRADE SIZE	PUNCH LOCATIONS		
				M1	M2		A	C1	C2
65kA	9.50 (241.3)	6.28 (159.5)	6.28 (159.5)	4.00 (101.6)	8.75 (222.3)	3/4 (19.0)	4.38 (111.2)	4.00 (101.6)	3.00 (76.2)

For the 380NN, 480NN, 600NN and 3Y600 only

These units come with a 3/4" conduit hub. This hub requires a 1 1/8" hole for proper installation. Note the hub supplied with the unit, when properly installed, ensures the enclosure maintains its NEMA 4 rating. Punch holes in locations indicated in Figure 8 for the conduit hub.

8. Phase, Neutral and Ground Connections



CAUTION: Prior to installation ensure the system configuration and voltage is equivalent to the voltage rating of the TransTrack2 unit being installed. Do not splice TransTrack2 conductors within the unit's enclosure or Manufacturer's warranty will be void.

Following all applicable National Electrical Code standards as well as state and local codes, connect phase, neutral* and ground to TransTrack2. Ensure that the conductor lengths are kept as short and straight as possible.

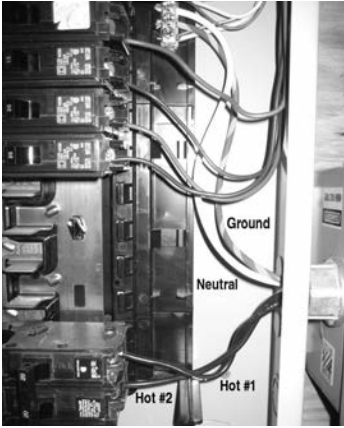

Install SPD directly adjacent to the point of termination to insure conductor length is as short as possible for optimum performance and protection.

9. Dry Relay Contact Connections

Units that come with Form "C" dry relay contacts (-M advanced monitoring option) provide status of the surge protective device. These contacts are for connection to a user-provided remote alarm and monitoring circuit. The relay contacts are rated 150VDC/125VAC with maximum switching power of 30WDC/60VA AC.

When input power is present on all phases, terminals "NO"(Normally Open) and "COM"(Common) are an open circuit and terminals "NC"(Normally Closed) and "COM" are a closed circuit. The contacts change state when the unit has encountered failure to one or more phases.

The installer must provide the appropriate raceway and wiring for the monitoring circuit, observing the restrictions and conduit openings illustrated in an earlier section of this manual.

These models come pre-wired with 30" of #20 AWG conductors. The red wire is for "NO", white wire is for "COM" and black wire is for "NC".

See figure 9 for the Form "C" wiring and contact configuration.

Use butt splices within the panelboard to connect the Form "C" leads to the user's monitoring circuits. Alternatively, install a junction box between the TranTrack2 and the panelboard to connect Form "C" leads to user's monitoring circuits. If the Form "C" contacts are not used, user has the option of either cutting off the leads or coiling up the leads and saving them for potential future use. Consult applicable local codes to ensure proper installation.

FIG. 9

Remote Monitoring Wire Connections

Contacts shown in de-energized state (alarm condition)

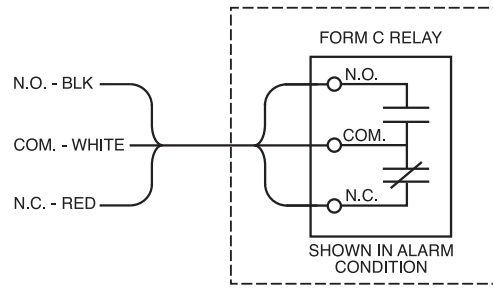

10. Verification and Power Up

Apply power to TransTrack2 by closing the over-current protection device or switch feeding the suppressor.

Fig. 10

TransTrack2 Diagnostics (Standard units)

Verify that all “Phase Protection Status” indicating lights are illuminated.



Fig. 11

TransTrack2 Diagnostics (Units with -M advanced monitoring option)

Verify that all “Phase Protection Status” indicating lights are illuminated. The “Check System” indicating light illuminates only upon failure of one or more phases (indicating an alarm condition). Audible alarm should not operate under normal conditions. The audible alarm can be "muted" by pressing the “ALARM SILENCE” button, which subsequently will illuminate the “ALARM SILENCED” light. Pressing the “ALARM SILENCE” button again will enable the alarm.



TROUBLESHOOTING

Your TransTrack2 system does not require scheduled maintenance. The unit's heavy-duty construction is designed to provide years of uninterrupted service. The unit contains no serviceable parts.

INDICATION	PROCEDURE
One or more phase protection status indicating lights are off, check system indicating light is on.	Verify that the input power feeding TransTrack2 is energized using a voltage tester. If power is present, contact factory for assistance: www.TPSSurge.com

INFORMATION	EXAMPLE
Model Number	TK-TT2-065-1S240-FL
Serial Number	16230-0112-002
Date of Purchase	January 1, 2012
Sales Order Number	16230
Description of Failure	"Check System" indicating light illuminated
Desired Action from Total Protection Solutions	Replace

WARRANTY STATEMENT

During the applicable warranty period, any Total Protection Solutions® surge protection device which fails due to defect in materials, workmanship, or any transient surge event to include lightning, shall be repaired or replaced at the expense of the manufacturer.

Prior to shipment of any suspect or known defective product a Return Material Authorization (RMA) number must be obtained. An official RMA number and shipping instructions can be obtained from the distributor where the product was originally purchased. Distributors can obtain the official RMA number by contacting the Total Protection Solutions Customer Service Department at 800-647-1911. Products arriving without an official RMA number will not be accepted and will be returned freight collect to the original point of shipment.

Products being returned with an official RMA number should be shipped by prepaid freight to the nominated point of return as shown on the RMA documentation.

Total Protection Solutions shall have no liability under this warranty for problems or defects directly or indirectly caused by misuse of the Product, alteration of the Product (including removal of any warning labels), accidents, improper installation, application, operation or improper repair of the Product.

THIS WARRANTY REPRESENTS THE ENTIRE WARRANTY OF TOTAL PROTECTION SOLUTIONS. ALL OTHER WARRANTIES EXPRESS OR IMPLIED, ORAL OR WRITTEN, INCLUDING, BUT NOT LIMITED TO, THE WARRANTIES OF MERCHANTABILITY AND FITNESS FOR A PARTICULAR PURPOSE ARE HEREBY DISCLAIMED. THE LIABILITY OF TOTAL PROTECTION SOLUTIONS, AT ITS SOLE OPTION, UNDER THIS WARRANTY IS EXPRESSLY LIMITED TO THE REPLACEMENT OR REPAIR OF THE DEFECTIVE PART THEREOF. IN NO EVENT SHALL TOTAL PROTECTION SOLUTIONS BE LIABLE OR RESPONSIBLE FOR SPECIAL, INCIDENTAL, OR CONSEQUENTIAL DAMAGES OF ANY KIND OR CHARACTER, NOR SHALL ITS LIABILITY EVER EXCEED THE PURCHASE PRICE PAID FOR SUCH DEFECTIVE PRODUCT.

Warranty period begins from date of original end-user purchase. This warranty is not transferable and may only be enforced by the original end user. Claims under this warranty must be submitted to Total Protection Solutions within thirty (30) days of discovery of any suspected product defect.

Warranty Period

TransTrack2® 25 years

**Total Protection
Solutions** 

PO Box 3760
Winter Park, FL 32790 USA
www.TPSSurge.com
1.800.647.1911