



Surge Protective Devices

**ServiceTrack ST Series:
080, 120, 160, 200, 240,
300 and 400**

Installation,
Operation and
Maintenance
Manual



**Read entire manual before
attempting installation**

TABLE OF CONTENTS

Before Installation	3 – 7
<i>System Configuration Verification</i>	3
<i>Wiring Connection Diagrams</i>	4
<i>Upstream Over-Current Protection Device</i>	5
<i>Conductor Routing</i>	5
<i>Conductor Sizing</i>	5
<i>Conduit Openings</i>	5 – 6
<i>Mounting</i>	7
Connection and Wiring Instructions	7 – 9
<i>Phase, Neutral and Ground Connections</i>	7
<i>Connecting Form C Dry Contacts</i>	8
<i>Neutral to Ground Filter Jumper</i>	9
<i>Disconnect Switch Connections</i>	9
<i>Verification and Power Up</i>	9
Troubleshooting	10
Technical Assistance	10
Standards and Listings	10
Returns and Warranty Procedures	10
Warranty Statement	11

BEFORE INSTALLATION



WARNING: HAZARDOUS VOLTAGES PRESENT Improper installation or misapplication may result in serious personnel injury and/or damage to electrical system. Read the complete installation instructions before proceeding with installation. Remove all power to the electrical panel before installing or servicing the surge protective device (SPD).



WARNING: Do not HIPOT the ServiceTrack ST unit or the electrical system that the ServiceTrack ST is connected to without disconnecting the ServiceTrack ST conductors including phases, neutral and ground.

IMPORTANT SAFETY INSTRUCTIONS All work must be performed by licensed and qualified personnel. The electrical system must be properly grounded in accordance with the U.S. National Electrical Code, state and local codes or other applicable codes for this SPD to function properly. This device is suitable for installation where the available short circuit current is 200,000 rms symmetrical amperes at 600VAC or less.

1. System Configuration Verification

Confirm that the voltage(s) and service configuration shown on the ServiceTrack ST product label are consistent with the voltage and service configuration of the facility. A model number is on the right side of the ServiceTrack ST unit. Each model number corresponds to the configurations printed in the table below:

Example of a SPD model number: TK-ST240-3Y208-FLB¹

MODEL NUMBER	NOMINAL VOLTAGE	L-N VOLTAGE RANGE	L-L VOLTAGE RANGE	CONFIGURATION
TK-STxxx-1P120	120	108-132	N/A	Single-Phase, 2-wire+ground
TK-STxxx-1P240	240	216-264	N/A	Single-Phase, 2-wire+ground
TK-STxxx-1S240	120/240	108-132	216-264	Split-Phase, 3-wire+ground
TK-STxxx-1S480	240/480	216-264	432-528	Split-Phase, 3-wire+ground
TK-STxxx-3Y208	120/208	108-132	187-229	Three-Phase WYE 4-wire+ground
TK-STxxx-3Y380	220/380	198-242	342-418	Three-Phase WYE 4-wire+ground
TK-STxxx-3Y400	230/400	207-253	360-440	Three-Phase WYE 4-wire+ground
TK-STxxx-3Y415	240/415	216-264	374-457	Three-Phase WYE 4-wire+ground
TK-STxxx-3Y480	277/480	249-305	432-528	Three-Phase WYE 4-wire+ground
TK-STxxx-3Y600	347/600	312-382	540-660	Three-Phase WYE 4-wire+ground
TK-STxxx-3D240	120/240	108-132 (A & C PHASES) 187-229 (B PHASE)	216-264	Three-Phase high-leg DELTA 4-wire+ground
TK-STxxx-240NN	240	N/A	216-264	Three-Phase DELTA 3-wire+ground
TK-STxxx-380NN	380 400 415	N/A	342-418 360-440 373-456	Three-Phase DELTA 3-wire+ground
TK-STxxx-480NN	480	N/A	432-528	Three-Phase DELTA 3-wire+ground
TK-STxxx-600NN	600	N/A	540-660	Three-Phase DELTA 3-wire+ground

¹Suffixes shown at the end of model number denote available options

Option Suffixes

xxx Denotes surge rating per phase 080, 120, 160, 200, 240, 300, or 400
 -B For surge counter
 -DN For non-fused disconnect
 -DF For fused disconnect
 -F For enhanced transient filter
 -L For component-level fusing
 -N For non-fused only available for 080, 120, 160
 -XX For NEMA 4X stainless steel enclosure

Notes: The power system operation frequency is between 47-63 HZ
 Confirm that the environmental conditions are consistent with the following ranges:
 • Ambient Temperatures: -40° and +158° (-40° to 70°C)
 • Relative Humidity: between 5% and 95%
 • Altitude: less than 13,000 feet (4000 m)



WARNING: Check to ensure that a proper bond is installed between neutral and ground at the transformer upstream from all 3-phase WYE, 3-phase high leg DELTA or split-phase ServiceTrack ST SPD (See NEC Article 250). If the transformer is not accessible, check the main service disconnect/panel for the N-G bond. Lack of a proper bond will damage ServiceTrack ST and void the warranty.

2. Wiring Connection Diagrams

Figures 1-5 show the electrical relationship between ServiceTrack ST and these five basic service configurations: Single phase, 2 wire; Split phase, 3 wire; Three phase, 4 wire WYE; Three phase, 3 wire DELTA and Three phase, 4 wire high leg DELTA.

Fig. 1: Single Phase, 2-Wire

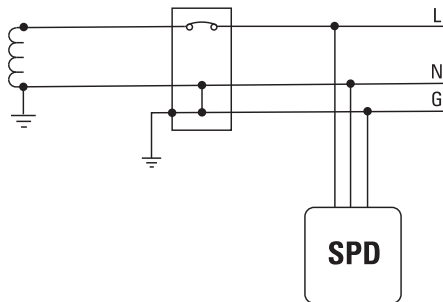

Fig. 2: Split Phase, 3-Wire

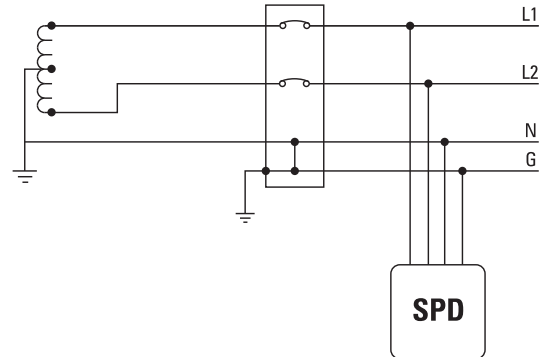

Fig. 3: 3-Phase, 4-Wire WYE

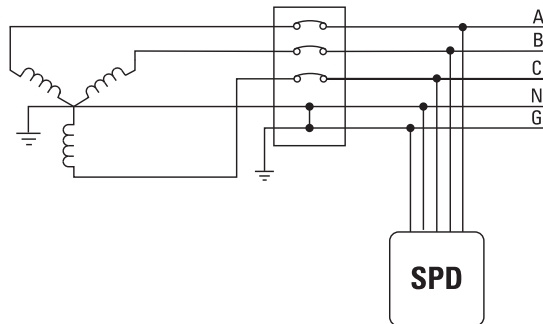
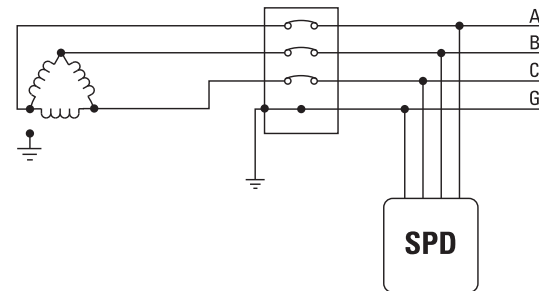

Fig. 4: 3-Phase, 3-Wire DELTA



Connections to the SPD are clearly identified. For 80kA models, connections are made via pigtail leads supplied with the unit.

For 120kA to 400kA models, connections are made to terminals inside the SPD enclosure. These terminals are marked with labels.

For 3 phase units phase A is marked as "PHASE A", phase B is marked as "PHASE B" and phase C is marked as "PHASE C". For split phase units, the phase connections are marked "Phase A" and "Phase B". For single-phase units, the phase connection is marked "Phase A". Neutral (if applicable) is marked as "Neutral Terminal" and ground is marked as "Equipment Ground Terminal".

Fig. 5: 3-Phase, 4-Wire High-Leg DELTA

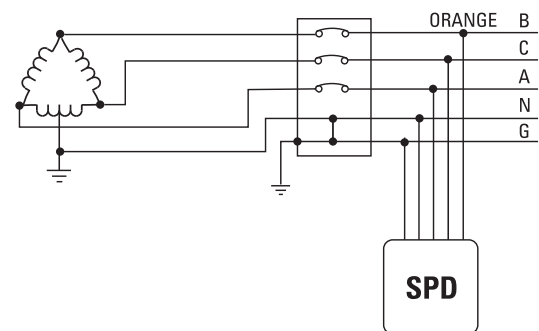

3. Upstream Over-Current Protection Device

The ServiceTrack ST is listed as a Type 1 SPD per UL 1449 3rd Edition, suitable for use in both Type 1 and Type 2 SPD applications. This means that the ServiceTrack ST can be installed on the line or load side of the main service disconnect. ServiceTrack ST are one-port devices and must be connected in parallel to the electrical system.

- Optional Component-Level Fusing Units: Model Numbers With “-L” Suffix

(Example model number: TK-ST080-3Y208-FL)

The ServiceTrack ST units are listed as Type 1 SPDs making them suitable for use in Type 1 and Type 2 SPD applications. These units DO NOT require an upstream over-current protection device and can be connected to the electrical distribution system bus. They have built-in over-current fusing rated at 200,000 rms symmetrical amperes at 600 VAC or less.

- Standard ServiceTrack ST Units: Model Numbers With “-N” Suffix - Type 2 SPD

(Example model number: TK-ST080-3Y208-NF)

These units MUST be connected to an upstream over-current protective device (circuit breaker, fuse or fused switch). The ratings for the upstream over-current protective device are as follows:

For 80kA, 120kA and 160kA units:

Class J or equivalent fused disconnect or circuit breaker rated at 60 amperes maximum for 80kA unit and 100 amperes maximum/600 volts maximum for 120kA and 160kA units.



CAUTION: Do not splice ServiceTrack ST conductors within the unit’s enclosure or Manufacturer’s warranty will be void. ServiceTrack ST’s performance will be limited severely if the conductors are (a) too long, (b) are of too small a wire gauge, (c) have too many bends or (d) have sharp bends.

4. Conductor Routing

The factors listed above should be addressed during the design of an installation to reserve a suitable place for ServiceTrack ST next to its point of connection to the electrical system. **The selected mounting location should allow for the shortest possible conductor runs and a direct route with a minimum of bends. If bends are required, they should be sweeping bends. Do not make sharp 90° bends for appearance purposes because they will severely decrease the effectiveness of ServiceTrack ST.**

Braiding or twisting conductors together using tie-wraps or electrical tape increases the protection performance of the device. One or two twists or braids of all conductors per foot and securely tie-wrap when conductor lengths must exceed 12”.

5. Conductor Sizing

Total Protection Solutions recommends installing ServiceTrack ST by using the following conductor sizes for phase, ground and neutral connections.

Example of a SPD model number: TK-ST240-3Y208-FL

PRODUCT LABEL DESIGNATION	SURGE CURRENT CAPABILITY	RECOMMENDED	CONDUCTOR SIZE	
			MAXIMUM	MINIMUM
TK-ST080-xxxxx	80kA/phase ¹	#10 AWG	#10 AWG	#10 AWG
TK-ST120-xxxxx	120kA/phase ²	#6 AWG	#2 AWG	#10 AWG
TK-ST160-xxxxx	160kA/phase ²	#6 AWG	#2 AWG	#10 AWG
TK-ST200-xxxxx	200kA/phase ²	#4 AWG	#2 AWG	#10 AWG
TK-ST240-xxxxx	240kA/phase ²	#4 AWG	#2 AWG	#10 AWG
TK-ST300-xxxxx	300kA/phase ²	#4 AWG	#2 AWG	#10 AWG
TK-ST400-xxxxx	400kA/phase ²	#4 AWG	#2 AWG	#10 AWG

¹ 80kA rated units are shipped with #10AWG leads. Note: Leads should be shortened during installation in order to minimize conductor length.

² For direct bus connection maximum wire size is recommended. Otherwise match wire size to the rating of the disconnect breaker.

Fig. 6 Conduit Openings and Enclosure/Mounting Dimensions

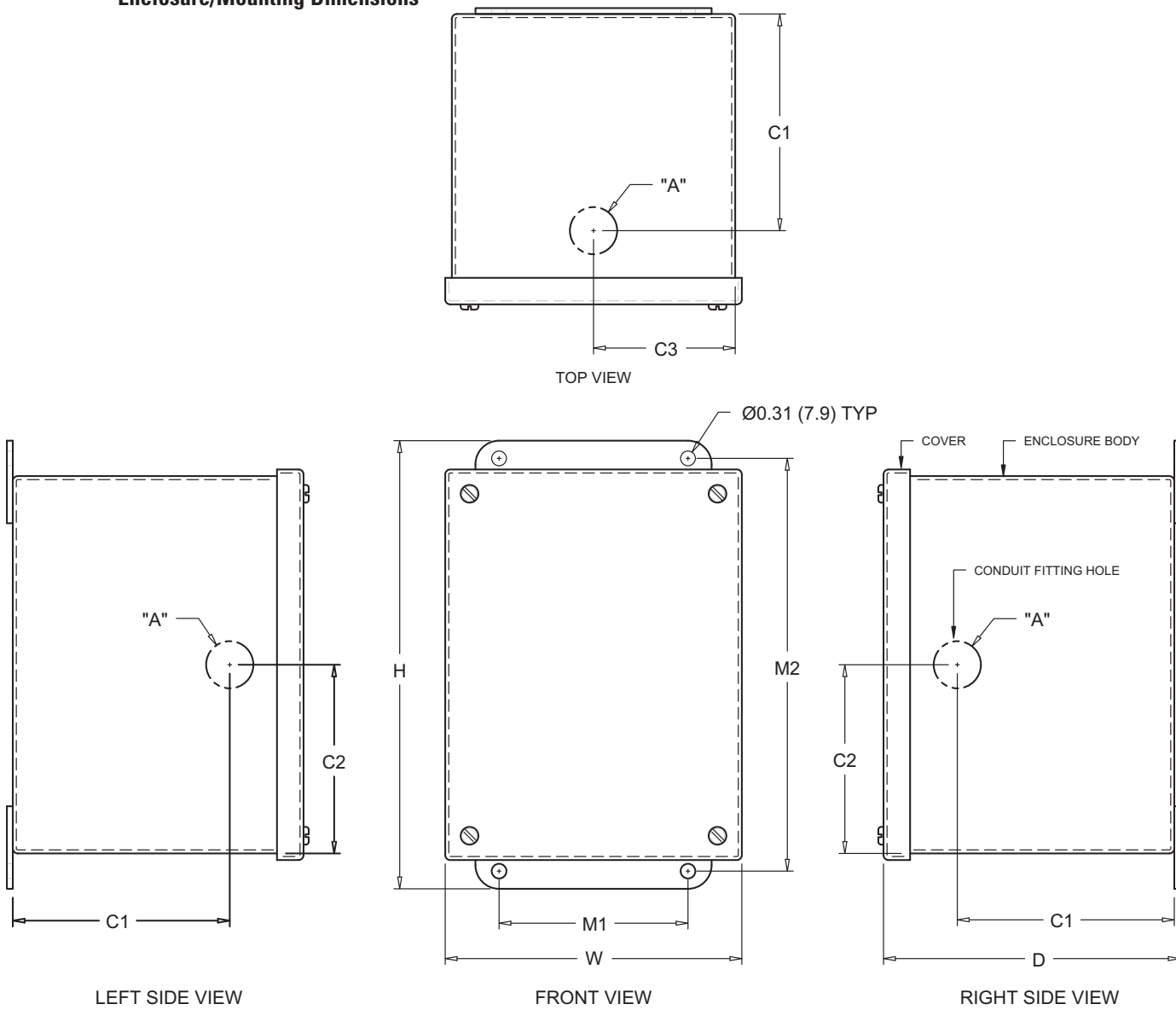

SURGE RATING	OVERALL DIMENSIONS - IN (mm)			MOUNTING HOLES		TRADE SIZE	CONDUIT FITTING PUNCH LOCATIONS		
	H	W	D	M1	M2	A	C1	C2	C3
80kA	9.50 (241.3)	6.28 (159.5)	6.28 (159.5)	4.00 (101.6)	8.75 (222.3)	3/4 (19.0)	4.38 (111.2)	4.00 (101.6)	3.00 (76.2)
120, 160kA	11.50 (292.1)	8.28 (210.3)	6.28 (159.5)	6.00 (152.4)	10.75 (273.1)	1.00 (25.4)	4.38 (111.2)	5.00 (127.0)	4.00 (101.6)
200 to 400kA	15.50 (393.7)	12.28 (311.9)	6.28 (159.5)	10.00 (254.0)	14.75 (374.6)	1.25 (31.7)	4.38 (111.2)	7.00 (177.8)	6.00 (154.2)

Conduit Openings

The 80kA unit comes with a 3/4" conduit hub. This hub requires a 1- 1/8" diameter hole for proper installation. The 120kA to 160kA units come with a 1"conduit hub. This hub requires a 1-11/32" diameter hole for proper installation. The 200kA to 400kA units come with a 1.25" conduit hub. This hub requires a 1.75" diameter hole for proper installation.

Note the hub supplied with the unit, when properly installed, ensures the enclosure maintains its NEMA 4 rating.

All conduits and fittings must be rated and properly installed such that the final installation maintains a NEMA 4 rating.

Punch holes in locations indicated in Figure 6 for the conduit hub.

7. Mounting

ServiceTrack ST SPD

For convenience all units are shipped with a mounting kit consisting of a hub, chase nipple, offset nipple, lock washers and wire bushing. Use the construction methods and hardware appropriate for your site. Install the conduit hub and other supplied hardware. Install conductors according to sections 4, 5 and 6, herein. See Figure 6 for enclosure and mounting dimensions.*

ServiceTrack ST Disconnect Switch Options

See the ServiceTrack ST Disconnect Switch Installation and Operations Manual for the proper mounting methods.

**Recommend avoiding wire-pulling lubricant due to potential for insulation deterioration, especially on such a short, small conductor installation.*

8. Indoor vs. Outdoor Installations

NEMA 4 enclosures are suitable for indoor or outdoor use. NEMA 4X (stainless steel) enclosures are suitable for corrosive environments as well. For direct sunlight applications, it is suggested to shade the unit. All conduits and fittings must be rated and properly installed so that the final installation maintains the NEMA rating.

CONNECTION AND WIRING INSTRUCTIONS

1. Phase, Neutral, and Ground Connections

NOTE: In order to connect the ServiceTrack ST, the cover of the unit must be removed. Use care when removing the cover, as there are wires, which run from components on the cover to inside the enclosure of the SPD. The monitor board (located on the backside of the cover) has a cable harness which routes into the enclosure. Additionally there is a ground jumper between the enclosure and the cover. Units supplied with a surge counter have a harness, which runs from the surge counter display to a core inside the unit.



CAUTION: Prior to installation, ensure the system configuration and voltage is equivalent to the voltage rating of the ServiceTrack ST unit being installed. Do not splice ServiceTrack ST conductors within the unit's enclosure or Manufacturer's warranty will be void.

Following all applicable National Electrical Code standards as well as state and local codes, connect phase, neutral* and ground to ServiceTrack ST. If suppressor is being installed on a breaker, installation electrician should install device directly adjacent to the breaker feeding the device to insure conductor length is kept to a minimum. The 80ka is supplied with #10 AWG conductors permanently attached. Should mounting conditions require extension of the supplied conductor(s), installation electrician may use a butt-splice or parallel solder with shrink-tube installation. In no event shall the electrician use a wire nut to make the extension as this will result in loss of suppressor's performance. Ensure that the conductor lengths are kept as short and straight as possible. The 120kA to 400kA units come with lugs that can be rotated to face in the direction of the cable exit by loosening the nut on the input terminal lugs in the SPD. Tighten all lugs to 20in-lb (2.2Nm). On all high-leg delta systems, the high-leg (color-coded orange according to NEC) must be connected to the Phase B of the SPD.

** The 3-wire plus ground Delta ServiceTrack ST does not have a neutral conductor.*

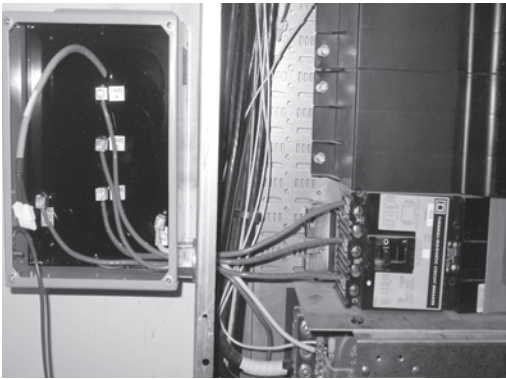

Install SPD directly adjacent to the point of termination to insure conductor length is as short as possible for optimum performance and protection.

2. Connecting Form C Dry Contacts

All ServiceTrack ST units come standard with one set of Form “C” dry relay contacts for the SPD status. These contacts are for connection to a user-provided remote alarm and monitoring circuit. The relay contacts are rated 65VDC/150VAC with maximum switching power of 30WDC/60VA AC. See Figure 7 for the form C contact configuration and terminal location on the monitor board. The annotations on the diagram match the markings on the terminal block.

When input power is present on all phases, terminals “NO” and “COM” are an open circuit and terminals “NC” and “COM” are a closed circuit. The contacts change state when the unit has encountered failure to one or more phases.

The installer must provide the appropriate raceway and wiring for the monitoring circuit, observing the restrictions and conduit openings illustrated in an earlier section of this manual. The installer must route the monitoring conductors to the terminal blocks on the door-mounted main monitoring board. Route the wires to allow the door to be opened and closed properly. Tighten screws on terminals to 3.5 in-lbs (0.4 Nm). This terminal block will accept wire sizes #28AWG to #16AWG. #18AWG to #20AWG is recommended.

Fig. 7 Remote Monitoring Terminal Block

Contacts shown in energized normal state.
(No fault condition)

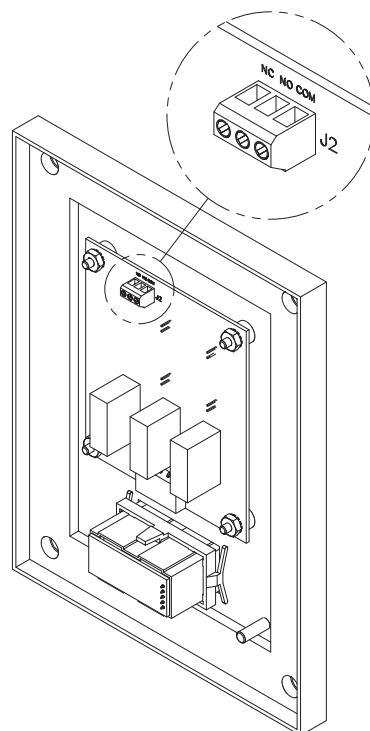

COVER REAR VIEW

3. Neutral to Ground Filter Jumper

All ServiceTrack ST models with enhanced transient filter, “-F” suffix, (which have a neutral connection) come with a green jumper wire, which loops out of the epoxy and connects the filter from neutral to ground. In certain medical applications or circuits which employ or contain Ground Fault Circuit Interrupting protection, this Neutral to Ground filter connection should be removed to avoid any nuisances that may trip the breaker.



WARNING: Prior to proceeding, ensure the SPD unit is fully disconnected and does not have voltage applied to its input terminals.

Removal is accomplished by cutting the green jumper wire. Once cut, both ends should be properly separated and insulated to prevent the ends from making inadvertent electrical contact.

4. Disconnect Switch Connections (-D option)

See the ServiceTrack ST Disconnect Switch Installation and Operations Manual for the proper connection methods.

5. Verification and Power Up



WARNING: It is recommended that the cover of the ServiceTrack ST unit along with its associated cabling be installed prior to applying power. The monitoring harness, which exits the epoxy and connects to J2 on the monitor board, contains line voltage when power is applied to the unit.

Apply power to ServiceTrack ST by closing the over current protection device or switch feeding the suppressor.



Fig. 8 Standard Monitoring

For Standard Units

Verify that all “Phase Protection Status” indicating lights are illuminated. The “Check System” indicating light illuminates only upon failure of one or more phases (indicating an alarm condition). Audible alarm should not operate under normal conditions. The audible alarm can be “muted” by pressing the “ALARM SILENCE” button, which subsequently will illuminate the “ALARM SILENCED” light. Pressing the “ALARM SILENCE” button again will enable the alarm.



Fig. 9 Surge Counter Option

For Units with Surge Counter Monitoring “-B” Option

The number of surges detected by the SPD is displayed on an eight-digit LCD display on the front of the ServiceTrack ST door. The LCD counter is battery backed to maintain the number of surges even during a power loss. Press the button on the counter to reset the surge count.

TROUBLESHOOTING

Your ServiceTrack ST system does not require scheduled maintenance. The unit's heavy-duty construction is designed to provide years of uninterrupted service. The unit contains no serviceable parts.

INDICATION	PROCEDURE
One or more phase protection status indicating lights are off, check system indicating light is on and form C alarm contacts have changed state	Verify that the input power feeding ServiceTrack ST is energized using a voltage tester. If power is present, contact factory for assistance: 800-647-1911.

TECHNICAL ASSISTANCE

Our staff is ready to support you and answer any questions.

Monday through Friday, 8:00 a.m. to 5:00 p.m. (EST) at 800-647-1911

STANDARDS AND LISTINGS

- Listed by UL to UL 1449 3rd Edition (2009 Revision) for Type 1 and Type 2 SPD applications, cUL, and UL 1283
- Meets Requirements for UL 96A
- Compliant to IEEE C62.41.1-2002, C62.41.2-2002 and C62.45-2002
- NFPA 70 [NEC], Article 285
- RoHS Compliant
- CE, IEC 61643-11-2011
- EMC Directive 2004/108/EC
- Low Voltage Directive 2006/95/EC

RETURNS AND WARRANTY PROCEDURES

ServiceTrack ST products are warranted for a period of 30 years from date of purchase. In the event that any module or sub-assembly within the SPD fails to perform as specified during the warranty period, call our Technical Support at 800-647-1911 to obtain a Return Material Authorization number. We will immediately ship a replacement for the defective parts free of charge (installation labor and site preparation excluded). Return the defective parts within 30 days of receiving the replacement. Failure to return the defective parts will result in billing for the replacement parts. To help expedite the return procedures, please have the following information at hand when you contact Total Protection Solutions:

INFORMATION	EXAMPLE
Model Number	TK-ST240-3Y208-FL
Serial Number	15478-0113-001
Date of Purchase	January 2, 2013 (1st week)
Sales Order Number	15478
Description of Failure	"Check System" indicating light illuminated
Desired Action	Replace

TPS WARRANTY STATEMENT

During the applicable warranty period, any Total Protection Solutions® surge protector device which fails due to defect in materials, workmanship, or any transient surge event to include lightning, shall be repaired or replaced at the expense of the manufacturer.

Prior to shipment of any suspect or known defective product a Return Material Authorization (RMA) number must be obtained. An official RMA number and shipping instructions can be obtained from the distributor where the product was originally purchased. Distributors can obtain the official RMA number by contacting the Total Protection Solutions Customer Service Department at 800-647-1911. Products arriving without an official RMA number will not be accepted and will be returned freight collect to the original point of shipment.

Products being returned with an official RMA number should be shipped by prepaid freight to the nominated point of return as shown on the RMA documentation.

Total Protection Solutions shall have no liability under this warranty for problems or defects directly or indirectly caused by misuse of the Product, alteration of the Product (including removal of any warning labels), accidents, improper installation, application, operation or improper repair of the Product.

THIS WARRANTY REPRESENTS THE ENTIRE WARRANTY OF TOTAL PROTECTION SOLUTIONS. ALL OTHER WARRANTIES EXPRESS OR IMPLIED, ORAL OR WRITTEN, INCLUDING, BUT NOT LIMITED TO, THE WARRANTIES OF MERCHANTABILITY AND FITNESS FOR A PARTICULAR PURPOSE ARE HEREBY DISCLAIMED. THE LIABILITY OF TOTAL PROTECTION SOLUTIONS, AT ITS SOLE OPTION, UNDER THIS WARRANTY IS EXPRESSLY LIMITED TO THE REPLACEMENT OR REPAIR OF THE DEFECTIVE PART THEREOF. IN NO EVENT SHALL TOTAL PROTECTION SOLUTIONS BE LIABLE OR RESPONSIBLE FOR SPECIAL, INCIDENTAL, OR CONSEQUENTIAL DAMAGES OF ANY KIND OR CHARACTER, NOR SHALL ITS LIABILITY EVER EXCEED THE PURCHASE PRICE PAID FOR SUCH DEFECTIVE PRODUCT.

Warranty period begins from date of original owner purchase. This warranty is not transferable and may only be enforced by the original end user. Claims under this warranty must be submitted to Total Protection Solutions within thirty (30) days of discovery of any suspected product defect.

Warranty Period

ServiceTrack® ST 30 years



Total Protection
Solutions



P.O. Box 3760
Winter Park, FL 32790 USA
www.TPSSurge.com
1.800.647.1911

